

Empore™

96-Well Solid Phase Extraction Plates

Plates Product List

Sorbent	Suggested Applications	Product Number	
		Standard 1.2 ml	Deep Well 2.5 ml
C8 Bonded Silica	Moderately nonpolar analytes	6014SD	6314SD
C18 Bonded Silica	Strongly nonpolar analytes	6015SD	6315SD
MPC (Mixed Phase Cation)	Moderately nonpolar and ionized analytes	6030SD	6330SD
UR (Universal Resin)	Mixed phase suitable for hydrophilic (acidic or basic) and moderately hydrophobic analytes	6045SD	6345SD
Filter Plate	Filtration of precipitated proteins and other particulates	6065	6360

Accessory	Product Number
96-Well Plate Vacuum Manifold	610
Replacement Gasket for 96-Well Plate Vacuum Manifold	615
Sealing Tape Pad for 96-Well Plates	660



Empore™ 96-Well Plate Vacuum Manifold

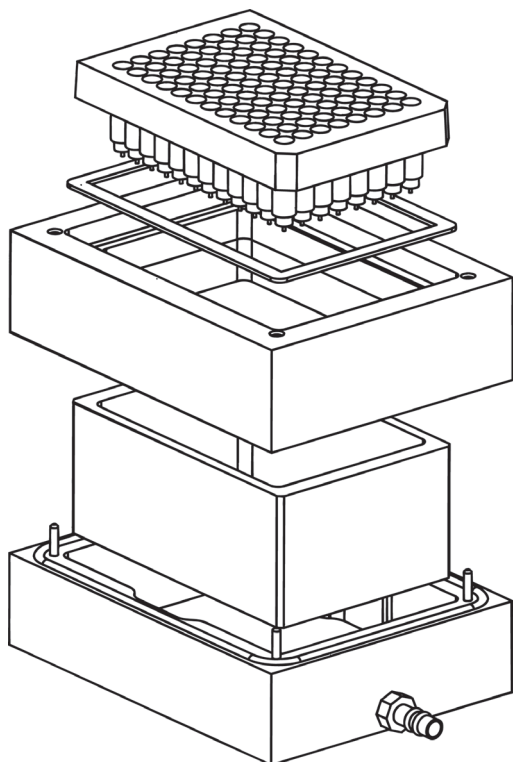

For further information on purchasing manifolds and accessories, please visit: www.dyneon.com/empore

Our Worldwide Commitment To Quality

Indicative of our commitment, all Dyneon design, development, production and service facilities have achieved global quality management certification. Production facilities have also received certification for their environmental management system. Please see the Dyneon website (www.dyneon.com) for the most up-to-date certification details.

Warranty, Disclaimer and Limited Remedy

Dyneon warrants that Product(s) will conform to Dyneon specifications for Product(s) at the time of shipment to Buyer. **Dyneon makes no other warranties, express or implied, including, but not limited to, any implied warranty of merchantability or fitness for a particular purpose or implied warranty arising out of a course of dealing, custom, or usage of trade.** If Product(s) does not conform to this warranty, Dyneon's only obligation, and Buyer's exclusive remedy, shall be refund of the purchase price for or replacement of the quantity of Product(s) shown to be nonconforming. Dyneon has no obligation under this warranty with respect to Product(s) that has been modified or damaged through misuse, abuse, accident, neglect, or mishandling by Buyer.

Limitation of Liability

Except where prohibited by law, Dyneon shall not under any circumstances be liable to Buyer for any direct, indirect, special, incidental, or consequential loss or damages (including, but not limited to, loss of profits, revenue, business, opportunity, or goodwill) resulting from or in any way related to Product(s) or Dyneon's sale of Product(s), regardless of the legal or equitable theory under which such loss or damages are sought, including breach of warranty or contract, negligence, or strict liability.

Technical Information and Data

Technical information and data, recommendations, and other statements provided by Dyneon are based on information, tests, or experience which Dyneon believes to be reliable, but the accuracy or completeness of such information is not guaranteed. Such technical information and data are intended for persons with knowledge and technical skills sufficient to assess and apply their own informed judgment to the information. No license under any Dyneon or third party intellectual property rights is granted or implied with this information.

Safety and Disposal

Always follow safe handling practices while processing Empore products as applicable to your use. Always wear appropriate personal protective equipment while processing Empore products as applicable to your use. Dispose of used Empore products per requirements of your process. Alteration or addition of other materials to Empore products may require unique disposal protocols. Always dispose of used product in accordance with federal, state and local requirements.

Note

Empore Solid Phase Extraction Products are intended for solid phase extraction during scientific research only. These products are not intended for use in medical devices or in assessment and treatment of clinical patients.

Distributor of Empore™ products in Belgium:

Sopachem nv/sa
Begoniastraat 17
B-9810 Eke
Belgium
Tel.: +32-9-2452550
Fax: +32-9-2522393

E-Mail: info.be@sopachem.com
Internet: www.sopachem.com



Dyneon GmbH & Co. KG
Bioanalytical Technologies Europe
Industrieparkstr. 1
D-84508 Burgkirchen/Germany
Tel.: +49-8679-7-4509
Fax: +49-8679-3992

Website: www.dyneon.com/empore
E-Mail: empore.europe@mmm.com

Dyneon and Empore are trademarks of 3M. Used under license.

© Dyneon 2008. All Rights Reserved.
Printed in Germany. Issued: 5/08
98-0504-2205-8



3M